

ISOMETER® isoHR685W-x-I-B

Insulation monitoring device for IT AC systems with galvanically connected rectifiers and inverters and for IT DC systems with isoData for logging measurement events with ISOsync for capacitive coupled IT-systems



ISOMETER® isoHR685W-x-I-B

Insulation Monitoring Device for IT AC systems with galvanically connected rectifiers and inverters and for IT DC systems with isoData for logging measurement events with ISOsync for capacitive coupled IT-systems



ISOMETER® isoHR685W-D-I-B

Device features

- ISOMETER® for IT AC systems with galvanically connected rectifiers or inverters and for IT DC systems (IT = unearthed systems)
- Automatic adaptation to the existing system leakage capacitance
- Combination of **AMP^{plus}** and other profile-specific measurement methods
- Two separately adjustable response value ranges of 1 kΩ...3 GΩ
- High-resolution graphic LC display
- Connection monitoring (monitoring of the measuring lines)
- Automatic device self test
- Graphical representation of the insulation resistance over time (isoGraph)
- History memory with real-time clock (buffer for three days) for storing 1023 alarm messages with date and time
- Current or voltage output 0(4)...20 mA, 0...400 µA, 0...10 V, 2...10 V (galvanically separated), which is analogous to the measured insulation value of the system
- Freely programmable digital inputs and outputs
- Remote setting via the Internet or Intranet (Webserver/Option: COMTRAXX® gateway).
- Remote diagnosis via the Internet (made available by Bender Service only)
- isoData: Continuous uninterrupted data transmission
- isoSync: Timely synchronization of measurement processes
- RS-485/BS (Bender sensor bus) for data exchange with other Bender devices via Modbus RTU protocol
- BCOM, Modbus TCP und web server
- ISONet: Internal separation of the ISOMETER® from the IT system to be monitored (e.g. if several IT systems are interconnected)
- ISONet priority: Permanent priority of a device within the network
- ISOloop: Special function for ring systems (all systems are coupled)

Product description

The ISOMETER® is an insulation monitoring device for IT systems in accordance with IEC 61557-8.

It is universally applicable in AC, 3(N)AC, AC/DC and DC systems. AC systems may include extensive DC-supplied loads (such as rectifiers, inverters, variable-speed drives).

Application

- AC, DC or AC/DC main circuits
- AC/DC main circuits with directly connected DC components, such as rectifiers, converters, variable-speed drives
- UPS systems, battery systems
- Heaters with phase control
- Systems including switch-mode power supplies
- coupled IT systems with high leakage capacitances
- Monitoring of long capacitive coupled lines

Function

The insulation monitoring device continuously monitors the entire insulation resistance of an IT system during operation and triggers an alarm when the value falls below a preset response value. To obtain a measurement the device has to be connected between the IT system (unearthed system) and the protective earth conductor (PE). A measuring current in the µA range is superimposed onto the system which is recorded and evaluated by a micro-controlled measuring circuit. The measuring time is dependent on the selected measurement profiles, the system leakage capacitance, the insulation resistance and possible system-related disturbances.

The response values and other parameters are set using a commissioning wizard or via different setup menus using the device buttons and a high-resolution graphical LC display. The selected settings are stored in a permanent fail-safe memory. Different languages can be selected for the setup menus as well as the messages indicated on the display. The device utilises a clock for storing fault messages and events in a history memory with time and date stamp. The settings can be password protected to prevent unauthorised changes.

To ensure proper functioning of connection monitoring, the device requires the setting of the system type 3AC, AC or DC and the required use of the appropriate terminals L1/+, L2, L3/-.

The insulation monitoring device isoHR685W-x-I-B is able to measure the insulation resistance reliably and precisely in all common IT systems (unearthed systems). Due to various applications, system types, operating conditions, application of variable-speed drives, high system leakage capacitances etc., the measurement technique must be able to meet varying requirements in order to ensure an optimised response time and relative uncertainty. Therefore different measuring profiles can be selected with which the device can optimally adjusted.

If the preset response value falls below the value of Alarm 1 and/or Alarm 2, the associated alarm relays switch, the LEDs ALARM 1 or ALARM 2 light and the measured value is shown on the LC display (in case of insulation faults in DC systems, a trend graph for the faulty conductor L+/L- is displayed). If the fault memory is activated, the fault message will be stored. Pressing the RESET button resets the insulation fault message, provided that the current insulation resistance displayed at the time of resetting is at least 25 % above the actual response value. As additional Information, the quality of the measuring signal and the time required to update the measured value are shown on the display. A poor signal quality (1-2 bars) may be an indication that the wrong measurement profile has been selected.

The ISOMETER® has an internal system isolating switch, which makes it possible to operate several ISOMETER®s in coupled IT systems. For this purpose, the ISOMETER®s are connected via an Ethernet bus. The integrated ISONet function ensures that only one ISOMETER® is actively measuring at a time, while the other devices are completely isolated from the system and waiting in standby mode for measuring permission.

The ISOMETER® is able to synchronise itself with other ISOMETER®s. This makes it possible to monitor capacitive coupled IT systems without interfering with each other.

Interfaces

- Communication protocol Modbus TCP/RTU
- BCOM to communicate with Bender devices via Ethernet
- BS bus for communication of Bender devices (RS-485)
- isoData to record and manage measured values
- Integrated web server to read measured values and for parameter setting

Device variants

isoHR685W-D-I-B

The device version isoHR685W-D-I-B features a high-resolution graphical LC display and control elements for direct operation of the device functions. It **cannot** be combined with an FP200.

isoHR685W-S-I-B

The isoHR685W-S-I-B device contains **no display** and **no operating unit**. It can **only be used in combination with FP200W** and is indirectly operated via this front panel.

Measurement method

AMPPlus The isoHR685W-x-I-B series uses the patented **AMPPlus** measurement method. This measurement method allows concise monitoring of modern power supply systems, also in case of extensive, directly connected DC components and high system leakage capacitances.

Standards

The ISOMETER® has been developed in compliance with the following standards:

- DIN EN 61557-8 (VDE 0413-8):2015-12
- IEC 61557-8:2014-12
- IEC 61557-8:2014/COR1:2016
- DIN EN 61557-8 Ber 1 (VDE 0413-8 Ber 1):2016-12

Certifications



Operating elements

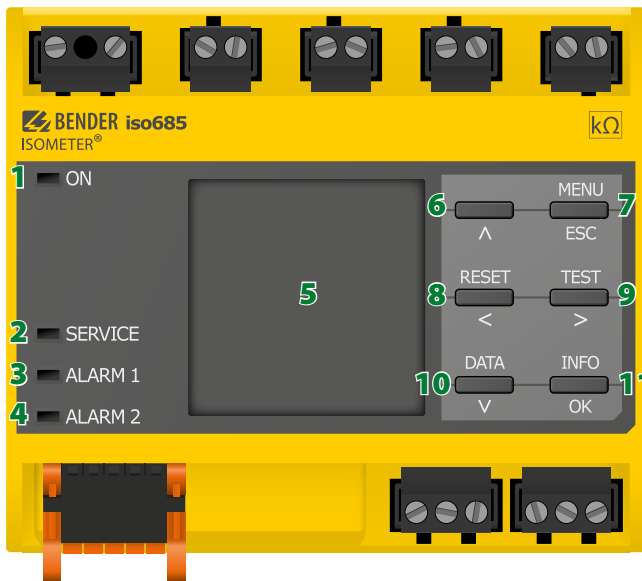

- 1 - ON The LED "ON" lights when the device is turned on.
- 2 - SERVICE The LED "SERVICE" lights when there is either a device fault or a connection fault, or when the device is in maintenance mode.
- 3 - ALARM 1 The LED "ALARM 1" lights when the insulation resistance of the IT system falls below the set response value R_{an1} .
- 4 - ALARM 2 The LED "ALARM 2" lights when the insulation resistance of the IT system falls below the set response value R_{an2} .
- 5 - Display The device display shows information regarding the device and the measurements.
- 6 - \wedge Navigates up in a list or increases a value.
- 7 - MENU Opens the device menu
ESC Cancels the current process or navigates one step back in the device menu.
- 8 - RESET Resets alarms.
< Navigates backwards (e.g. to the previous setting step) or selects a parameter.
- 9 - TEST Starts the device self test.
> Navigates forwards (e.g. to the next setting step) or selects a parameter.
- 10 - DATA Indicates data and values.
v Navigates down in a list or reduces a value.
- 11 - INFO Shows information.
OK Confirms an action or a selection.

Wiring diagram

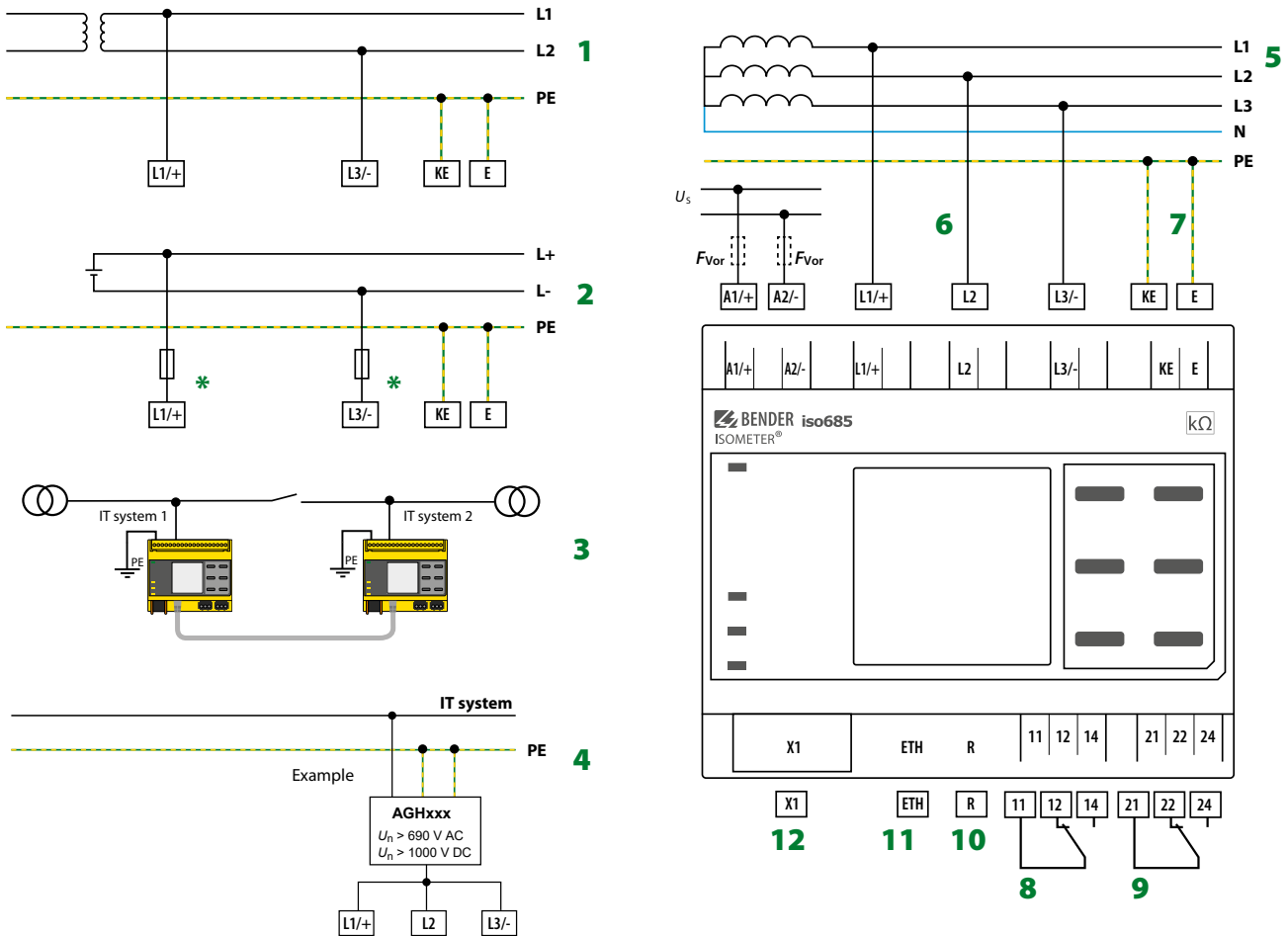

- 1 - Connection to an AC system U_n
- 2 - Connection to a DC system U_n
- 3 - Linked with two IT systems which can be interconnected via a coupling switch. Information regarding the state of the coupling switch is not necessary.
- 4 - Connection to an IT system with coupling device
- 5 - Connection to a 3(N)AC system
- 6 - Connection to the IT system to be monitored (L1/+, L2, L3/-)
- 7 - Separate connection of KE, E to PE

- 8 - (K1) Alarm relay 1, available changeover contacts
- 9 - (K2) Alarm relay 2, available changeover contacts
- 10 - Switchable resistor R for RS-485 bus termination
- 11 - Ethernet interface
- 12 - Digital interface
- * - For systems > 690 V and with overvoltage category III a fuse for the connection to the system to be monitored must be provided.
Recommendation: 2A screw-in fuses.

Provide line protection!

According to DIN VDE 0100-430, a line protection shall be provided for the supply voltage.

NOTE

According to DIN VDE 0100-430, devices for protection against a short-circuit can be omitted for the coupling of terminals L1/+, L2 and L3/- to the IT system ≤ 690 V to be monitored if the wiring is carried out in such a manner as to reduce the risk of a short-circuit to a minimum. Ensure short-circuit-proof and earth-fault-proof wiring.

The connecting lines L1/+, L2, L3/- to the system to be monitored must be carried out as spur lines. No load current may be conducted through the terminals.

For UL applications:

Use 60/70°C copper lines only!
UL and CSA application require the supply voltage to be protected via 5 A fuses.

ISOsync for coupled IT systems

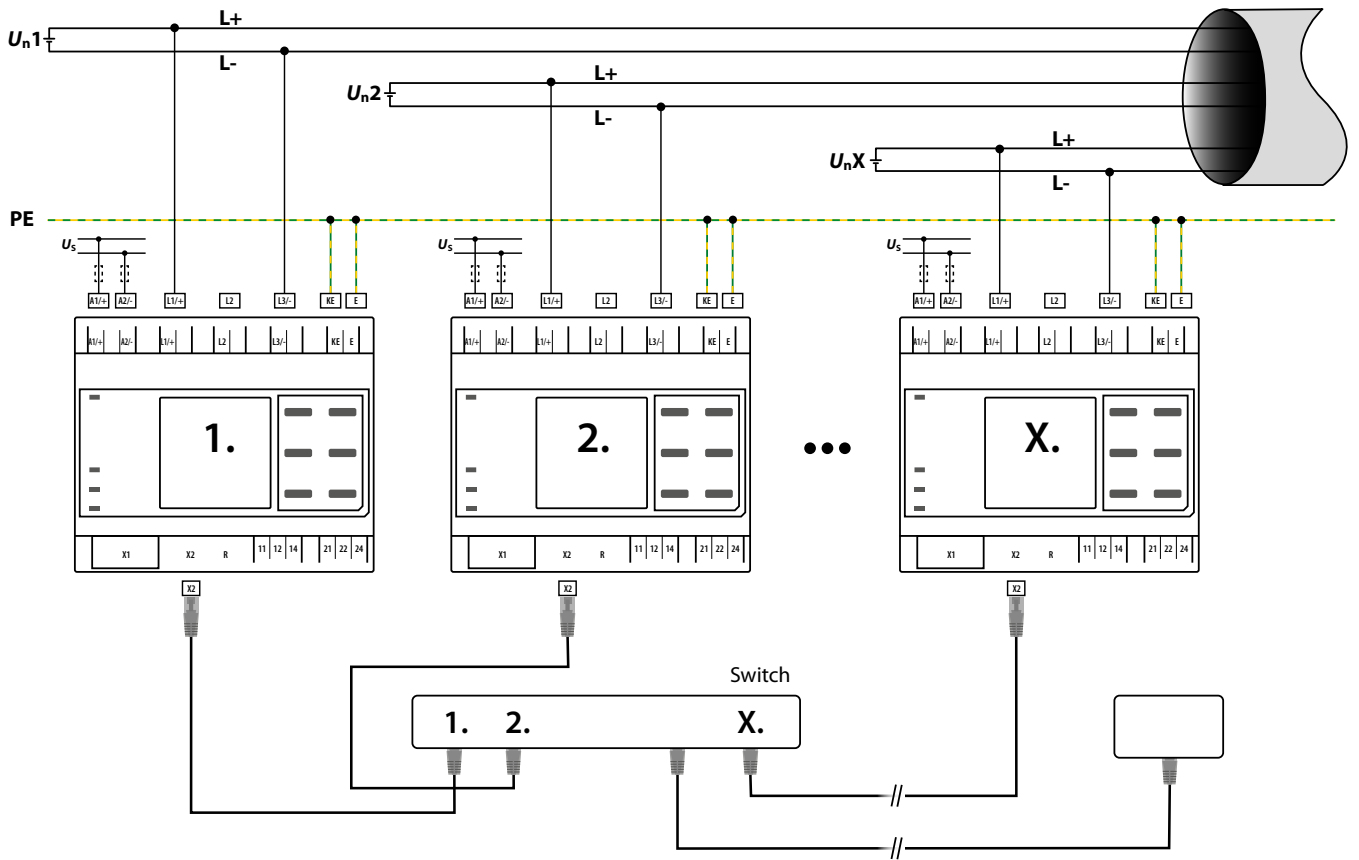

Digital interface X1

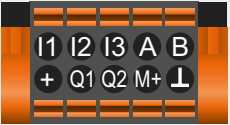
Digital interface	Terminal	Description
 <p>X1</p>	I1...I3	Configurable digital inputs (e.g. test, reset, ...)
	A, B	Serial interface RS-485, termination by means of a DIP switch R.
	+	Supply voltage of the inputs and outputs I, Q and M. Electrical overload protection. Automatic shutdown in the event of short circuits and transients (resettable). When supplied via an external 24 V source, A1/+, A2/- must not be connected.
	Q1, Q2	Configurable digital output
	M+	Configurable analogue output (e.g. measuring instrument)
	⊥	Reference potential ground

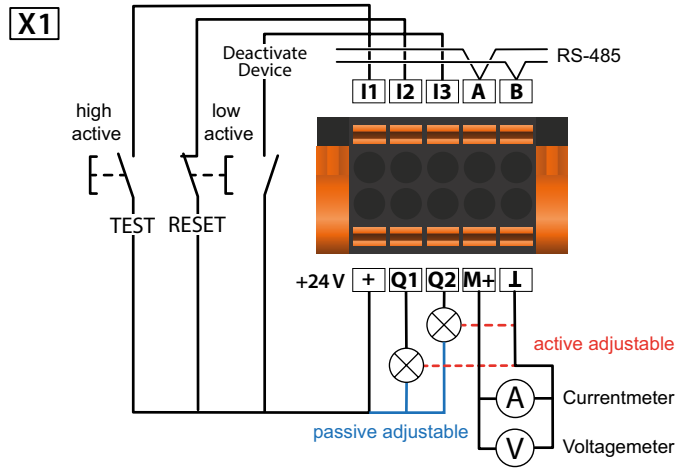

Dimension diagram isoHR685W-x-I-B

Dimensions in mm

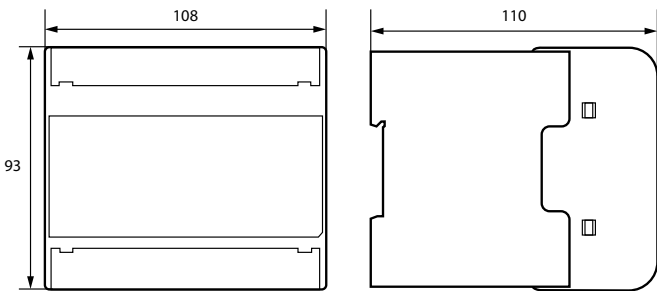

Dimension diagram Panel cut-out FP200

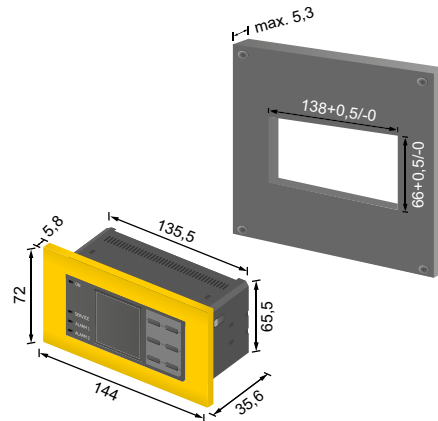

Dimensions in mm

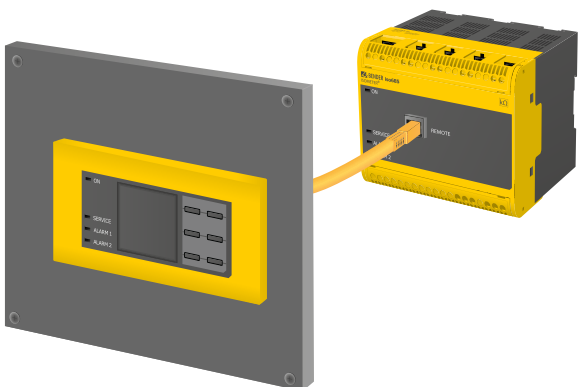

Connection to FP200



Ordering information

Nominal system voltage range U_n		Supply voltage U_s		Display	Type	Art. no.
AC	DC	AC	DC			
0...1000 V 0.1...460 Hz	0...1300 V	24...240 V; 50...400 Hz	24...240 V	integrated	isoHR685W-D-I-B 	B91067025W
				detached	isoHR685W-S-I-B + FP200W ¹⁾ 	B91067225W

¹⁾ Only available in combination

Accessories

Description	Art. no.
A set of screw terminals ¹⁾	B91067901
A set of push-wire terminals	B91067902
Enclosure accessories (terminal cover, 2 mounting clips) ¹⁾	B91067903
Transparent cover 144x72 (IP65) for FP200 ²⁾	B98060005
BB bus 6TE connector	B98110001

¹⁾ included in the scope of delivery

²⁾ If the “transparent front cover 144x72 (IP65)” is used, the cutout in the control cabinet must be increased in height from 66 mm to 68 mm (+ 0.7 / -0 mm).

Suitable system components

Description	Type	Art. no.
Device version without display	isoHR685W-S-I-B	B91067125W
Display for front panel mounting	FP200W	B91067904W
Coupling devices	AGH150W-4	B98018006
	AGH204S-4	B914013
	AGH520S	B913033
	AGH676S-4	B913055

Suitable measuring instruments on request!

Technical data

Insulation coordination acc. to IEC 60664-1/IEC 60664-3

Definitions:	
Measuring circuit (IC1)	L1/+, L2, L3/-
Supply circuit (IC2)	A1, A2
Output circuit 1 (IC3)	11, 12, 14
Output circuit 2 (IC4)	21, 22, 24
Control circuit (IC5)	(E, KE), (X1, ETH, X3, X4)
Rated voltage	1300 V
Overvoltage category	II
Rated impulse voltage:	
IC1/(IC2-5)	8 kV
IC2/(IC3-5)	4 kV
IC3/(IC4-5)	4 kV
IC4/IC5	4 kV
Rated insulation voltage:	
IC1/(IC2-5)	1000 V
IC2/(IC3-5)	300 V
IC3/(IC4-5)	300 V
IC4/IC5	300 V
Pollution degree outside ($U_n < 690$ V)	3
Pollution degree outside ($U_n > 690 < 1000$ V)	2
Safe isolation (reinforced insulation) between:	
IC1/(IC2-5)	Overvoltage category III, 1000 V
	Overvoltage category II, 1300 V
IC2/(IC3-5)	Overvoltage category III, 300 V
IC3/(IC4-5)	Overvoltage category III, 300 V
IC4/IC5	overvoltage category III, 300 V
Voltage tests (routine test) acc. to IEC 61010-1	
IC2/(IC3-5)	AC 2.2 kV
IC3/(IC4-5)	AC 2.2 kV
IC4/IC5	AC 2.2 kV

Supply voltage

Supply via A1/+, A2/-:

Supply voltage range U_s	AC/DC 24...240 V
Tolerance of U_s	-30...+15 %
Maximum permissible input current of U_s	650 mA
Frequency range of U_s	DC, 50...400 Hz ¹⁾
Tolerance of the frequency range of U_s	-5...+15 %
Power consumption, typically DC	≤ 12 W
Power consumption, typically 50/60 Hz	≤ 12 W/21 VA
Power consumption, typically 400 Hz	≤ 12 W/45 VA

Supply via X1:

Supply voltage U_s	DC 24 V
Tolerance of U_s	DC -20...+25 %

IT system being monitored

Nominal system voltage range U_n	AC 0...1000 V, 3AC 0...690 V, DC 0...1300 V AC/DC 0...1000 V (for UL applications)
Tolerance of U_n	AC/DC +15 %
Frequency range of U_n	DC 0.1...460 Hz
Max. AC voltage U_n in the frequency range $f_n = 0.1...4$ Hz	$U_{-max} = 50 \text{ V/Hz}^2 * (1 + f_n^2)$

Response values

Response value R_{an1} (Alarm 1)	1 kΩ...3 GΩ
Response value R_{an2} (Alarm 2)	1 kΩ...3 GΩ
Relative uncertainty (acc. to IEC 61557-8)	dependent on the profile, ±15 %, at least ±1 kΩ
Hysteresis	25 %, at least 1 kΩ

Time response

Response time t_{an} at $R_f = 0.5 \times R_{an}$ ($R_{an} = 10$ kΩ) and $C_e = 1$ μF according to IEC 61557-8	profile dependent, typ. 10 s (see diagrams in manual)
Response time DC Alarm at $C_e = 1$ μF	profile dependent, typ. 5 s (see diagram in manual)
Start-up delay $T_{start-up}$	0...120 s

Measuring circuit

Measuring voltage U_m	profile dependent, ±10 V, ±50 V (see profile overview)
Measuring current I_m	≤ 403 μA
Internal resistance R_i, Z_i	≥ 124 kΩ
Internal resistance on decoupled systems (inactive by I/O, inactive by ISOnet or cut-off)	typ. 50 MΩ
Permissible extraneous DC voltage U_{fz}	≤ 1500 V
Permissible system leakage capacitance C_e	profile dependent, 0...1000 μF

Measuring ranges

Measuring range f_n	0.1...460 Hz
Tolerance measurement of f_n	±1 % ±0.1 Hz
Voltage range measurement of f_n	AC 25...690 V
Measuring range U_n (without an external coupling device)	AC 25...1000 V; 3AC 25...690 V; DC 0...1300 V
Voltage range measurement of U_n	AC/DC 10...1000 V ²⁾
Tolerance measurement of U_n	±5 % ±5 V
Measuring range C_e	0...1000 μF
Tolerance measurement of C_e	±10 % ±10 μF
Frequency range measurement of C_e	DC, 30...460 Hz
Min. insulation resistance measurement of C_e	depending on the profile and coupling mode, typ. > 10 kΩ

Display

Indication	graphic display 127 x 127 pixels, 40 x 40 mm ²⁾
Display range measured value	0.1 kΩ...20 MΩ
Operating uncertainty (according to IEC 61557-8)	±15 %, at least ±1 kΩ

LEDs

ON (operation LED)	green
SERVICE	yellow
ALARM 1	yellow
ALARM 2	yellow

In-/Outputs (X1-Interface)

Cable length X1 (unshielded cable)	≤ 10 m
Cable length X1 (shielded cable, shield connected to earth PE on one side J-Y(St)Y min. 2x0,8)	≤ 100 m
Total max. supply output current via X1./X1.GND for each output	max. 1 A
Total max. supply output current via A1/A2 in total on X1	max. 200 mA
Total max. supply output current via A1/A2 in total on X1 between 16.8 V and 40 V	$I_{LmaxX1} = 10 \text{ mA} + 7 \text{ mA/V} * U_s$ ³⁾ (negative values are not allowed for I_{LmaxX1})

Digital inputs (I1, I2, I3)

Number	3
Operating mode, adjustable	active high, active low
Functions	off, test, reset, deactivate device, start initial measurement
Voltage	Low DC -3...5 V, High DC 11...32 V
Voltage tolerance	± 10 %

Digital outputs (Q1, Q2)

Number	2
Operating mode, adjustable	active, passive
Functions	off, Ins. alarm 1, Ins. Alarm 2, connection fault, DC- alarm ⁴⁾ , DC+ alarm ⁴⁾ , symmetrical alarm, device fault, common alarm, measurement complete, device inactive, DC offset alarm
Voltage passive	DC 0...32 V, active DC 0/19.2...32 V

Analogue output (M+)

Number	1
Operating mode	linear, midscale point 28 kΩ/120 kΩ
Functions	insulation value, DC shift
Current	0...20 mA (< 600 Ω), 4...20 mA (< 600 Ω), 0...400 μA (< 4 kΩ)
Voltage	0...10 V (> 1 kΩ), 2...10 V (> 1 kΩ)
Tolerance related to the current/voltage final value	± 20 %

Technical data (continued)

Interfaces

Field bus:

Interface/protocol	web server/Modbus TCP/BCOM
Data rate	10/100 Mbit/s, autodetect
Max. number of Modbus requests	<100/s
Cable length	≤ 100 m
Connection	RJ45
IP address	DHCP/manual* 192.168.0.5*
Network mask	255.255.255.0*
BCOM address	system-1-0
Function	communication interface

ISOnet

Number of ISOnet devices	2...20 dev
Max. nominal system voltage ISOnet	AC, 690 V/DC, 1000V

ISOloop

Number of ISOloop devices	2...20 dev
---------------------------	------------

ISOsinc:

Number of ISOsinc devices	≤ 50
---------------------------	------

Sensor bus:

Interface/Protocol	RS-485/BB bus
Data rate mode 1	9.6 kBaud/s
Cable length (depending on the baud rate)	≤1200 m
Cable: twisted pair, one end of shield connected to PE	recommended: J-Y(St)Y min. 2x0.8
Connection	terminals X1.A, X1.B
Terminating resistor	120 Ω, can be connected internally
Device address	1...90

Switching elements

Number of switching elements	2 changeover contacts
Operating mode	N/C operation/N/O operation
Contact 11-12-14/21-22-24	off, Ins. alarm 1, Ins. Alarm 2, connection fault, DC- alarm ⁴⁾ , DC+ alarm ⁴⁾ , symmetrical alarm, device fault, common alarm, measurement complete, device inactive, DC offset alarm
Electrical endurance under rated operating conditions, number of cycles	10,000

Contact data acc. to IEC 60947-5-1:

Utilisation category	AC-13 / AC-14 / DC-12 / DC-12 / DC-12 / DC-12
Rated operational voltage	230 V / 230 V / 24 V / 48 V / 110 V / 220 V
Rated operational current	5 A / 3 A / 1 A / 1 A / 0.2 A / 0.1 A
Rated insulation voltage ≤ 2000 m NN	250 V
Rated insulation voltage ≤ 3000 m NN	160 V
Minimum contact rating	1 mA at AC/DC ≥ 10 V

Environment/EMC and temperature range

EMC	IEC 60533, IEC 61326-2-4 ⁵⁾
Operating temperature	-25...+55 °C
Transport	-40...+85 °C
Long-term storage	-40...+70 °C

Classification of climatic conditions acc. to IEC 60721 (related to temperature and relative humidity)

Stationary use (IEC 60721-3-3)	3K23
Transport (IEC 60721-3-2)	2K11
Long-term storage (IEC 60721-3-1)	1K22

Classification of mechanical conditions acc. to IEC 60721:

Stationary use (IEC 60721-3-3)	3M12
Transport (IEC 60721-3-2)	2M4
Long-term storage (IEC 60721-3-1)	1M12
Area of application	≤3000 m NN

Connection

Connection type pluggable screw terminal or push-wire terminal

Screw-type terminals:

Nominal current	≤ 10 A
Tightening torque	0.5...0.6 Nm (5...7 lb-in)
Conductor sizes	AWG 24-12
Stripping length	7 mm
rigid/flexible	0.2...2.5 mm ²
flexible with ferrules, with/without plastic collar	0.25...2.5 mm ²
Multiple conductor, rigid	0.2...1 mm ²
Multiple conductor, flexible	0.2...1.5 mm ²
Multiple conductor, flexible with ferrule without plastic sleeve	0.25...1 mm ²
Multiple conductor, flexible with TWIN ferrule with plastic sleeve	0.5...1.5 mm ²

Push-wire terminals:

Nominal current	≤ 10 A
Conductor sizes	AWG 24-12
Stripping length	10 mm
rigid/flexible	0.2...2.5 mm ²
flexible with ferrules, with/without plastic collar	0.25...2.5 mm ²
Multiple conductor, flexible with TWIN ferrule with plastic sleeve	0.5...1.5 mm ²

Push-wire terminals X1:

Nominal current	≤ 8 A
Conductor sizes	AWG 24-16
Stripping length	10 mm
rigid/flexible	0.2...1.5 mm ²
flexible with ferrule without plastic sleeve	0.25...1.5 mm ²
flexible with ferrule with plastic sleeve	0.25...0.75 mm ²

Other

Operating mode	continuous operation
Mounting (0°)	display oriented, cooling slots must be ventilated vertically ⁶⁾
Degree of protection internal components	IP40
Degree of protection terminals	IP20
DIN rail mounting acc. to	IEC 60715
Screw fixing	3 x M4 with mounting clip
Enclosure material	polycarbonate
Flammability class	V-0
ANSI code	64
Dimensions (W x H x D)	108 x 93 x 110 mm
Documentation number	D00261
Weight	< 390 g

¹⁾ At a frequency > 200 Hz, the connection of X1 and remote must be insulated. Only permanently installed devices which at least have overvoltage category CAT2 (300 V) may be connected.

²⁾ Indication limited outside the temperature range -25...+55 °C.

³⁾ U_s [Volt] = supply voltage ISOMETER®

⁴⁾ Only for U_n ≥ 50 V.

⁵⁾ This is a class A product. In a domestic environment, this product may cause radio interference. In this case, the user may be required to take corrective actions.

⁶⁾ Recommendation: Mounting position 0° (display-oriented, cooling slots must be ventilated vertically). At mounting position 45°, the max. operating temperature is reduced by 10 °C. At mounting position 90°, the max. operating temperature is reduced by 20 °C.

„W“ option data deviating from the standard version

Devices with the suffix „W“ feature increased shock and vibration resistance. The electronics is covered with a special varnish to provide increased protection against mechanical stress and moisture. (Refer the following information box)

Rated operational current switching elements	max. 3
--	--------



Combination of ISOMETER® sensor variant with an FP200W:
The requirements of the „W“ option will only be fulfilled if the ISOMETER® sensor variant is mounted on DIN rail and connected to the FP200W via the patch cable. Refer also to the quick-start guide FP200 (document number D00169).



Bender GmbH & Co. KG

Londorfer Straße 65 • 35305 Grünberg • Germany
Tel.: +49 6401 807-0 • info@bender.de • www.bender.de



BENDER Group